

SILENCER®

ELITE Series

Service Manual



Proudly designed and manufactured in the great United States

ELITE Service Manual v1.0

Revised: 01/01/2020

Copyright © 2020

Global Focus Marketing & Distribution, Ltd.

2280 Springlake # 106

Dallas, Texas 75234

800-323-4306

<https://gfmd.com/support/>

This manual contains confidential and proprietary information, and is provided to Silencer[®] customers under license. Receipt of this manual does not convey any rights to reproduce or disclose its contents in any form. Global Focus Marketing & Distribution, Ltd. (herein known as GFMD, Ltd) retains all rights to this manual and its contents. Reproducing and/or disclosure of its contents is strictly prohibited, and may violate Copyright and/or Patent laws.

While every effort has been made to ensure the completeness and accuracy of this manual, Global Focus Marketing & Distribution, Ltd. will not be liable for failure to follow standard safety precautions.

Printed in the United States of America.

Table Of Contents

Chapter 1	Getting Started	1-1
	Scope	1-1
	Unpacking And Inspection.....	1-1
	Setup.....	1-1
	Rotor Installation	1-2
Chapter 2	About The ELITE	2-1
	Purpose	2-1
	Description	2-1
Chapter 3	Using The ELITE.....	3-1
	Orientation.....	3-1
	Controls	3-1
	Operation	3-2
	Set Point	3-2
	Program Store	3-3
	Program Recall	3-3
	Settings Menu	3-4
	Operation Tips	3-5
	Operation Flowchart	3-6
Chapter 4	Cleaning	4-1
Chapter 5	Troubleshooting	5-1
	Status Codes	5-1
	Error Reset.....	5-1
	Troubleshooting Table	5-1
Chapter 6	Functional Description	6-1
	AC Power Distribution	6-1
	DC Power Distribution	6-1
	Operator Interface Circuits.....	6-1
	Lid Interlock Circuit	6-2
	Lid Unlocking Circuit.....	6-2
	Tachometer Feedback Circuit	6-2
	Motor Control Circuit	6-3
	Motor Driver Temperature Sense Circuit	6-3
	Motor Current Sense Circuit	6-3
	Fan Control Circuit	6-3
	Motor Braking Circuit.....	6-3

Chapter 7	Technical Illustrations.....	7-1
Chapter 8	Parts Replacement Procedures	8-1
	Precautions	8-1
	Equipment	8-1
	Motor.....	8-1
	Display/Control PCB	8-3
	Power PCB	8-3
	Lidlock Assembly	8-3
	Drive / Brake Relay	8-3
	Drive / Brake Relay Socket.....	8-4
Chapter 9	Warranty	9-1
Appendix A	Specifications	A-1
	Performance Specifications.....	A-1
	Unit Specifications.....	A-2
Appendix B	R. C. F. Chart	A-3
Appendix C	Service Log	A-5
Appendix D	Replacement Parts List	A-6
Appendix E	Lid Release Tool.....	A-7
Appendix F	Motor Hall Effect Sensor Testing	A-8

List of Illustrations

- Figure 3.1 Control Panel Layout3-1
- Figure 3.2 Operation Flowchart3-6
- Figure 7.1 Wiring Diagram7-1
- Figure 7.2 Power PCB Schematic7-2
- Figure 7.3 Power PCB Layout7-3
- Figure 7.4 Display / Control PCB Schematic7-4
- Figure 7.5 Display / Control PCB Layout7-5
- Figure 7.6 Drive / Brake Relay Socket Wiring.....7-6
- Figure 8.1 Front Panel Retaining Screws8-2
- Figure 8.2 Motor Gasket Removal8-2
- Figure 8.3 Motor Retaining Screws8-2

Chapter 1

Getting Started

SCOPE

This manual contains information with regards to application, installation, and operation of the Silencer[®] ELITE benchtop centrifuge, and must be read prior to setup or operation of the centrifuge.

UNPACKING AND INSPECTION

Your new Silencer[®] centrifuge is packed in a specially designed shipping carton. Upon arrival please check the condition of carton and note any damage. Keep all packing materials for the warranty period of the centrifuge.

After unpacking your Silencer[®] carefully inspect it for damage. It is your responsibility to report all damages to the transportation company and filing, if necessary, any damage claims.

At this point take a moment to ensure you have received the correct rotor, tube adapters, etc. If not or if you have any questions regarding compatibility with your tubes, please contact GFMD, Ltd. at 800-323-4306 before proceeding.

WARNING

Do not operate this equipment in a combustible atmosphere!

SETUP

For your own safety and to prevent damage to the centrifuge, be sure to read this manual before continuing with setup or operation of this centrifuge.

For smooth operation and long equipment life, choose a stable, level bench top.

Avoid sources of heat and/or moisture such as sinks, water baths, heating ducts, and direct sunlight. A suitable environment is 20° to 25° C (68° to 77° F) with a relative humidity range of 30% to 60%. The minimum clearance is 6" on all sides. A cooler ventilated location and leaving the lid open between cycles will allow longer and/or more frequent cycles without overheating of samples. The maximum number of cycles that may be run consecutively will depend upon operating speed, set time, ventilation around the centrifuge, and ambient temperature. Samples that may be adversely affected by being warmed to 39°C during centrifugation should be centrifuged in a refrigerated centrifuge such as the Silencer[®] TANK-R.

Plug the power cord into a properly grounded outlet and turn on main power interrupt (on back of unit next to power cord). For safety, equipment life, and proper performance, your Silencer[®] ELITE's power requirements are 115V AC, 5 amperes, 60Hz. The power cord must be UL listed or CSA certified, 18 AWG, and 6' 7" or less in length.

Getting Started

WARNING

Operating the centrifuge without proper grounding can cause dangerous electrical conditions and could result in serious operator injury!

CAUTION

Operation of centrifuge on an emergency power circuit can cause damage to electronic circuits.

CAUTION

Operation of centrifuge on a power strip increases ground resistance and can cause damage to electronic circuits.

ROTOR INSTALLATION

Insert the rotor onto the motor shaft ensuring the alignment pin in the motor shaft fits correctly into the alignment groove in the bottom of the rotor. The rotor must be installed correctly for proper operation.

Replace the rotor securing nut. The nut must be securely tightened.

Chapter 2

About The ELITE

PURPOSE

The Silencer[®] ELITE is a quiet, general purpose centrifuge designed to be used to accelerate sample separation through the application of relative centrifugal force (RCF). This product is not intended to diagnose, treat, cure or prevent any disease.

DESCRIPTION

The direct drive system employs a powerful, specially designed, balanced, brushless motor ensuring a smooth quiet operation spanning the full speed range of the instrument. This design also promotes long bearing life and eliminates brush maintenance, thereby reducing operating costs.

Excellent stability against imbalance is achieved due to special vibration absorbing drive assembly mounts.

The operator and the ELITE are protected by several safety features:

- The centrifuge cannot be started with the lid open.
- The centrifuge will not run if the lidlock fails to securely lock.
- Once the rotor is in motion the lid cannot be opened until the rotor has stopped.
- The see-through high-strength lid allows the operator to view the rotor chamber without opening the lid.
- The rotor chamber is strong and easy to clean.

For complete equipment specifications see Appendix A.

Chapter 3

Using The ELITE

ORIENTATION

Take time now to acquaint yourself with the ELITE's displays and controls. The basic operation is very simple and the controls are mostly self-explanatory.

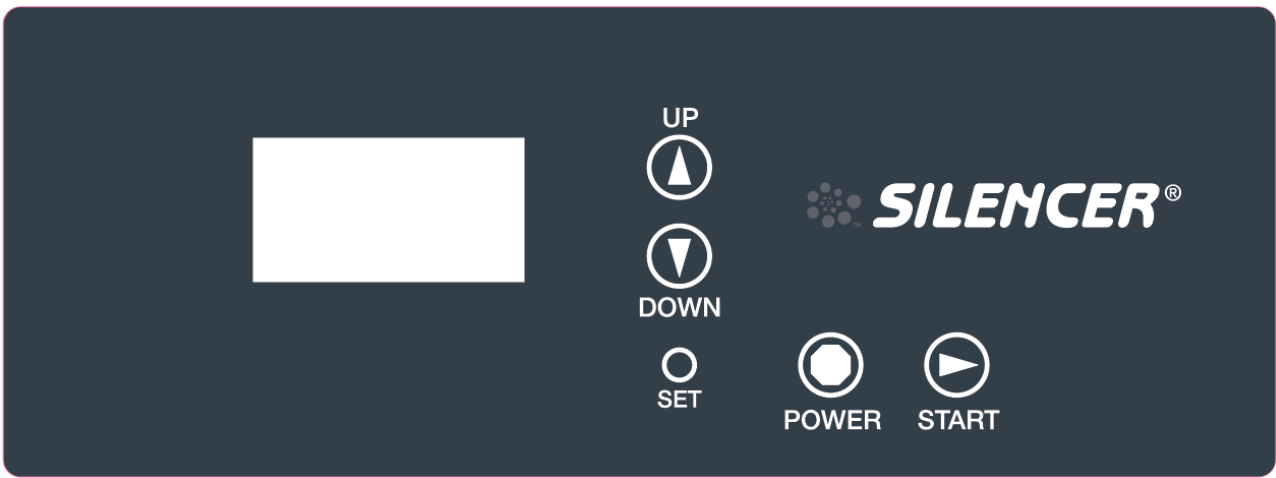

Figure 3.1



WARNING

Turning the power off does not remove power to the centrifuge. Remove all power to the unit by unplugging the power cord.

CONTROLS

POWER

Press the POWER button once to bring the unit out of SLEEP mode and into STANDBY mode. This unlocks the lid and turns the display on. Pressing the POWER button while the power is on turns the display off and puts the unit into a low power SLEEP mode.

Pressing the POWER button during a run cycle stops the cycle.

Pressing the POWER button while in any SET mode cancels and returns the centrifuge to the STANDBY MODE.

SET

Press to enter the SET POINT mode

UP

Press the UP button to increase the value of the selected item.

Using The ELITE

DOWN

Press the DOWN button to decrease the value of the selected item.

START

If pressed when the unit is in the STANDBY mode, the START button will start the run cycle, which is indicated by the display going into inverse mode (dark background and light text).

Pressing the START button while in any SET mode will accept changes and return to the STANDBY mode.



WARNING

Do not operate this equipment in a combustible atmosphere!

OPERATION

Chapter 1 must be read and the ELITE must be setup accordingly before continuing.

Press the POWER button to bring the centrifuge out of the SLEEP mode, turn the display on, and unlock the lid.

2000 RPM / 605 x G
5 MINUTES

The set speed and time defaults to the last saved speed and time setting. The settings can be changed in the SET POINT mode or a saved program can be recalled in the PROGRAM RECALL mode.

Open the lid and load your samples, taking care to maintain a balanced load.

Close the lid and press the START button. The lidlock will engage, the display will show the actual speed, and the centrifuge will accelerate to the set speed. Upon reaching the set speed the time will start counting down, and the display will show the time remaining.

When the set time has elapsed, the centrifuge will decelerate to a stop.

When the rotor has come to a complete stop the lidlock will release, and display will revert back to set speed and time.

SET POINT

The SET POINT mode shows the current speed and time settings.

NOTE: The current settings can not be changed if the centrifuge is in the LOCKED mode.

Using The ELITE

```
SET POINTS
▶ RPM: 2000 RCF: 0605
  TIME: 005 MINUTES
```

The currently selected item is indicated with an arrow. To select another parameter for modification press and release the SET button.

Modify the selected parameter by pressing the UP or DOWN button.

Cancel changes by pressing the POWER button.

Accept the changes and return to the STANDBY mode by pressing the START button.

If you wish to save these settings press and hold the SET button for approximately two seconds to enter the PROGRAM STORE mode (indicated by three short beeps).

PROGRAM STORE

The PROGRAM STORE mode displays the three program locations.

```
PROGRAM - STORE
▶ PROG NUMBER: 1
  PROG NUMBER: 2
  PROG NUMBER: 3

RPM    TIME
2000   005
```

The currently selected program is indicated with an arrow. Press the SET button to select another program location.

The current saved speed and time for the selected program is displayed below the program list.

Press the POWER button to cancel programming and return to the STANDBY mode.

Press the START button to store the settings into the selected program location and return to the STANDBY mode.

PROGRAM RECALL

Press and hold the SET button for approximately 2 seconds to enter the PROGRAM RECALL mode (indicated by three short beeps).

The PROGRAM RECALL mode displays the three selectable programs.

Using The ELITE

```
PROGRAM - RECALL
▶ PROG NUMBER: 1
  PROG NUMBER: 2
  PROG NUMBER: 3

RPM    TIME
2000   005
```

The currently selected program is indicated with an arrow. Press the SET button to select another program location.

The programmed speed and time for the selected program is displayed below the program list.

Press the POWER button to cancel program selection and return to the STANDBY mode.

Press the START button to accept the program selection and return to the STANDBY mode.

SETTINGS MENU

Press the POWER button to put the centrifuge into the SLEEP mode (indicated by one beep).

Press and hold the SET button while pressing and releasing the POWER button.

Continue to hold the SET button until the unit enters the SETTINGS MENU (indicated by 2 short beeps)

Release the SET button.

```
SETTINGS MENU
▶ BEEPS (EOR):      1
  BEEPS (error):   5
  RCF MODE:        OFF
  BRAKES:          9
  OPTIONAL EOR LED: 2
```

The SETTINGS MENU shows the current user settings.

The currently selected item is indicated with an arrow. To select another parameter for modification press and release the SET button.

Modify the selected parameter by pressing the UP or DOWN button.

Accept the changes and return to the STANDBY mode by pressing the START button.

BEEPS (EOR)

This determines the number of times the centrifuge will beep at the end of each run. The default is 1 and the allowable settings are 0 to 9.

Using The ELITE

BEEPS (error)

This determines the number of times the centrifuge will beep when an error is incurred. The default is 5 and the allowable settings are 5 to 9.

RCF MODE

This allows the operator to choose how speed will be set. If the RCF MODE is OFF the speed is set by RPM in 100 RPM increments. If the RCF MODE is ON the speed is set by RCF in increments of 10xg.

BRAKES

This adjusts the braking level. The default is 9 and the allowable settings are OFF to 9.

OPTIONAL EOR LED

This setting has no effect unless the optional End of Run Light is installed. This setting determines the length of time (in minutes) that the green LED will remain on at the end of each run. The default is 2 and the allowable settings are 0 to 99.

OPERATION TIPS

- Do not drop or slam the lid!
- Use the emergency lid lock release only for emergencies.
- Only use the supplied emergency lid lock release tool.
- Unplug the centrifuge before using the emergency lid lock release tool.
- Leave the lid open between cycles.

If there are any questions regarding operation please contact GFMD, Ltd. at 800-323-4306.

Using The ELITE

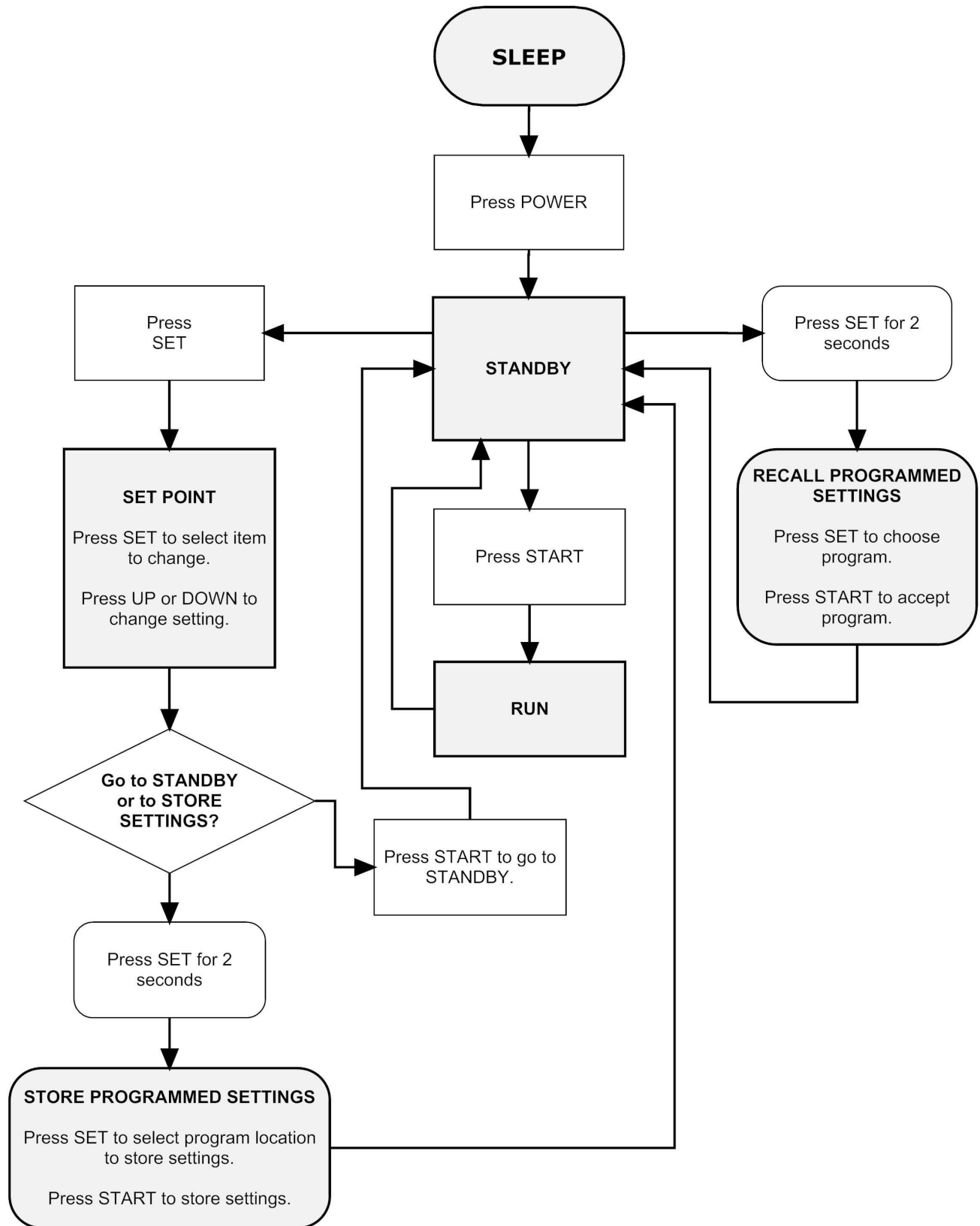

Figure 3.2

Cleaning

⚠ WARNING Turning the power off does not remove power to the centrifuge. Remove all power to the unit by unplugging the power cord.

⚠ WARNING Standard safety precautions for handling of biological hazards must be followed!

CAUTION Do not get any liquids into the top of the motor. Many disinfectants are extremely corrosive and may damage the motor.

CAUTION Allowing liquid levels in the rotor chamber to rise to the bottom of the motor seal may result in serious damage to the centrifuge.

- The rotor must be removed from the centrifuge for disinfecting. The rotor can be disinfected with PH neutral disinfectants if rinsed and dried prior to use. The disinfectant manufacturer's instructions must be followed. Do not use if the disinfectant manufacturer warns against use on aluminum, stainless steel, or neoprene.
- Clean tube breakages and spills immediately and thoroughly. The interior can be disinfected with PH neutral disinfectants. Disinfectants such as bleach can be used for the rotor chamber only. The interior must be rinsed and dried thoroughly before using the centrifuge. Use water sparingly when rinsing, as the motor seal is not watertight.
- Residue from broken tubes is highly abrasive. Operating the centrifuge with residue from broken tubes can damage the finish on the accessories and rotor chamber possibly compromising their protection from chemicals.

A white powder inside the rotor chamber is indicative of the debris from broken plastic tubes not being thoroughly removed prior to operating.

A charcoal grey residue inside the rotor chamber is indicative of the debris from broken glass tubes not being thoroughly removed prior to operating.

- The exterior should be kept clean with the use of a mild soap and a damp (not wet) lint-free cloth. The centrifuge must be dried thoroughly before using.

CAUTION Use of disinfectants with PH >8 is not recommended.

Chapter 5

Troubleshooting

STATUS CODES

This is a list of error codes and the brief description that the centrifuge displays when an error is encountered. Check under symptoms for more details.

ERROR: 1.1	Indicates no power is getting to the motor.
ERROR: 1.2	Indicative of low line voltage or a momentary sag.
ERROR: 1.3	Indicative of a momentary drop or loss of line voltage. (LOCKING)
ERROR: 7.1	Check the lid safety interlock switch for proper alignment and continuity.
ERROR: 7.2	Check the lid safety interlock switch for proper alignment and continuity.
ERROR: 7.3	Do not attempt to open the lid until the unit has stopped. (LOCKING)
ERROR: 8	Ensure the line voltage is stable & the circuit isn't overloaded.

ERROR RESET

Pressing the front panel POWER button will reset most error messages.

Locking errors indicate an issue that needs to be addressed before the unit is put back into service. Unplug the centrifuge for approximately 20 seconds in order to reset locking errors.

TROUBLESHOOTING TABLE

SYMPTOM	The lid remains locked and the displays are not illuminated when the POWER button is pressed.	
	POSSIBLE CAUSES	POSSIBLE SOLUTIONS
	No power to the ELITE.	Ensure the ELITE is plugged in, there is power to the receptacle, and the main power switch is on.
	The fuses are blown.	Replace the fuses with 5A, 250V, time delay fuses. If the fuses blow again contact GFMD, Ltd. at 800-323-4306 for assistance.

SYMPTOM	Will not start when the START button is pressed and “ERROR: 7.1” is displayed.	
	POSSIBLE CAUSES	POSSIBLE SOLUTIONS

Troubleshooting

	The lid safety interlock switch is defective or misaligned.	Check the lid safety interlock switch for proper alignment and continuity.
	Lid is not closed completely preventing the lid from locking.	Make sure the lid is completely closed.
	Locking mechanism is mechanically binding.	Check for proper lid lock solenoid movement.
	Lid lock safety interlock switch is defective or misaligned.	Check the lid lock safety interlock switch for proper alignment and continuity.

SYMPTOM	Will not start when the START button is pressed and “ERROR: 1.1” is displayed.	
	POSSIBLE CAUSES	POSSIBLE SOLUTIONS
	Indicates no power is getting to motor.	<p>Ensure the motor wires are securely connected to the Drive/Brake Relay Socket.</p> <p>Ensure the motor wires from the Drive/Brake Relay Socket are properly connected to BLACK1, GREEN1, and RED1 on the Power PCB.</p> <p>The Drive/Brake Relay’s drive contacts may be pitted or worn.</p> <p>The Drive/Brake Relay may be loose in the relay socket.</p>
	Bad Hall Effect Sensor in the motor.	See Appendix F for testing procedure.
	The motor tachometer cable is unplugged.	Ensure the motor tachometer cable is connected to MOTOR1 on the Power PCB.
	The power sagged so the unit did not start before the bootstrap capacitors discharged.	Check electrical outlet for stable line voltage, and ensure that the circuit isn’t overloaded.

Troubleshooting

SYMPTOM	Shuts down and a status code is displayed.	
	POSSIBLE CAUSES	POSSIBLE SOLUTIONS
	ERROR: 1.2 - Indicative of low line voltage or a momentary sag in line voltage.	Check for a loose power cord connection to the outlet, an overloaded circuit, or line voltage below 110 VAC.
	ERROR: 1.3 - Indicative of a momentary drop in line voltage or loss of line voltage.	Reset the unit by turning the main power switch off for approximately 20 seconds and then back on.
	ERROR: 7.2 - Indicates the lid safety interlock switch failed during a run cycle or an attempt was made to open the lid during the run cycle.	<p>If there was not an attempt to open the lid before the unit came to a complete stop, see suggestions for the centrifuge not starting and giving an “ERROR: 7.1” error.</p> <p>If someone attempted to open the lid during the run cycle, please wait until the unit has come to a complete stop before opening the lid. Manually releasing the lid during the cycle creates a hazardous condition and is an OSHA safety violation.</p>
	ERROR: 7.3 - Indicates the lid safety interlock switch failed during deceleration or an attempt was made to open the lid before the unit came to a complete stop.	<p>If there was not an attempt to open the lid before the unit came to a complete stop, see suggestions for the centrifuge not starting and giving an “ERROR: 7.1” error.</p> <p>If someone attempted to open the lid during the run cycle, please wait until the unit has come to a complete stop before opening the lid. Manually releasing the lid during the cycle creates a hazardous condition and is an OSHA safety violation.</p>
	ERROR: 8 - Indicates the speed was too erratic.	Check electrical outlet for stable line voltage, and ensure that the circuit isn’t overloaded.

Troubleshooting

SYMPTOM	The sample temperature is exceeding 39°C.	
	POSSIBLE CAUSES	POSSIBLE SOLUTIONS
	The rotor chamber heat extraction fan isn't turning on.	Verify that the fan is turning on when the cycle is started, continues to run during the cycle, and for several minutes after the rotor comes to a complete stop.
	Cycle times are too long, operating speed is too high, and /or cycles are too frequent.	Lower the operating speed (see Appendix B R.C.F. Chart for appropriate speed), shorten spin time, and/or allow more cooling time between cycles with the lid open.
	Centrifuge is under a heat vent.	Relocate the centrifuge away from heat vents.
Centrifuge's immediate ambient environment is warm due to other equipment.	Relocate unit away from heat producing equipment.	

Chapter 6

Functional Description

The ELITE consists of the following interactive circuits:

- AC Power Distribution
- DC Power Distribution
- Operator Interface Circuits
- Lid Interlock Circuit
- Lid Unlocking Circuit
- Tach Feedback Circuit
- Motor Control Circuit
- Motor Driver Temperature Sense Circuit
- Motor Current Sense Circuit
- Fan Control Circuit
- Motor Braking Circuit

AC POWER DISTRIBUTION

Power for the ELITE is 115 VAC and is supplied through a CSA approved line cord with a three prong grounding plug and power entry module FL1 which contains the 5 ampere fuses, a double pole power interrupt switch, and a medical version EMC filter. The output of FL1 is applied to the Power PCB.

DC POWER DISTRIBUTION

The Power PCB supplies unregulated HV (approximately +160 VDC), +15 VDC regulated, and +5 VDC regulated (VCC). The common for all DC power supplies is VSS.

The line voltage enters through connector ACPOWER1 pins 1 and 3, and is applied to MOV1, MOV2, MOV3, and bridge rectifier D1.

Output of bridge D1 is applied through VR1 and VR2 to filter capacitors C25 and C26, supplies unregulated HV to the motor control pulse width modulation circuitry, and to the power module PS1.

The output of PS1 provides regulated +15 VDC. The +15VDC is applied to regulator U4. U4 output is regulated +5 VDC (VCC). VCC is used by the logic circuitry on the Power PCB and is supplied to the Display / Control PCB through CONTROL1 pin 2.

OPERATOR INTERFACE CIRCUITS

The Display / Control PCB handles setting and visual status of power on, run activation, time, speed, and displaying error messages.

Functional Description

The POWER push button switch is applied to U4 pin 3 and U4 output at pin 14 is applied to U1 pin 43. This alternates the centrifuge between a low power sleep mode and standby mode. When the centrifuge is in the run mode the POWER button can also be used as a STOP button.

The START push button switch is applied to U4 pin 4 and U4 output at pin 13 is applied to U1 pin 44. The START button is used to start the run mode.

The SET push button switch is applied to U4 pin 7 and U4 output at pin 10 is applied to U1 pin 3. The SET button is used to enter the set point mode, the program store mode, the program recall mode, and to select items in those modes. See Chapter 3 for details on the SET button usage.

The UP push button switch is applied to U4 pin 5 and U4 output at pin 12 is applied to U1 pin 1. The UP button is used to increment the value of items selected with the SET button.

The DOWN push button switch is applied to U4 pin 6 and U4 output at pin 11 is applied to U1 pin 2. The DOWN button is used to decrement the value of items selected with the SET button.

LID INTERLOCK CIRCUIT

The lidlock assembly has two switches wired in series. One indicates if the lid is open or closed and the other indicates if the lock is engaged or disengaged. If either switch is open pin 2 of SAFTY1 on the Power PCB will be high. This signal is applied through pin 4 of CONTROL1 to pin 3 of U2 on the Display / Control PCB. The output of U2 at pin 14 is applied to U1 pin 10. This input is used to verify the switches status prior to starting and to generate an error if either switch opens after the unit starts. The pull-up resistor (R6) ensures the default status assumes the lid is open in the event the lidlock assembly is unplugged or there is a break in the circuit.

LID UNLOCKING CIRCUIT

The default condition of the lidlock assembly is locked. Unlocking of the lid is handled by energizing a solenoid. Initially full voltage is applied to the solenoid to energize it. The unlocking voltage is controlled from pin 41 of U1 on the Display / Control PCB. This signal is applied to U2 pin 4. The output of U2 at pin 13 is supplied through CONTROL1 pin 8 to the gate of Q1. Q1 applies VSS to the solenoid.

After the lid is unlocked a lower voltage is applied to the solenoid to hold it energized and the unlocking voltage is turned off. The solenoid holding voltage is controlled from pin 9 of U1 on the Display / Control PCB. This signal is applied to U2 pin 2. The output of U2 at pin 15 is supplied through CONTROL1 pin 6 to the gate of Q2. Q2 applies VSS to the solenoid through the dropping resistor R7.

TACH FEEDBACK CIRCUIT

There are three Hall Effect sensors in the motor. The sensor outputs are supplied to U1 on the Power PCB through MOTOR1. U1 uses this input to determine motor position and to generate an RPM output. The motor position information is used to control the three-phase motor driver

Functional Description

U5 on the Power PCB. The RPM output is sent to the Display / Control PCB through CONTROL1 pin 3.

There are 4 pulses per revolution so RPM can be calculated by measuring duration of a tachometer pulse with an oscilloscope and applying the formula $((1/\text{duration in seconds}) * 60) / 4$. The speed can also be checked using a frequency counter and applying the formula $((\text{tachometer frequency in seconds}) * 60) / 4$.

MOTOR CONTROL CIRCUIT

When a run cycle is started a signal from pin 12 of U1 on the Display / Control PCB is applied through CONTROL1 pin 5 to U1 pins 4 to enable the run mode.

A PWM value from U1 pin 16 on the Display / Control PCB is applied through CONTROL1 pin 10 to pin 6 of U1 on the Power PCB. The PWM pulse is at a constant frequency and a duty cycle that is adjusted based upon the TACH feedback to control motor speed.

MOTOR DRIVER TEMPERATURE SENSE CIRCUIT

Thermistor output of the three-phase motor driver (U5) at pin 14 is inversely proportional to the temperature of U5. This voltage is applied to the temperature limit input of U1 at pin 5 through comparator U3B. This is a negative feedback loop that counteracts the PWM pulse to limit power to the motor if the driver is too warm due to inadequate heat dissipation.

MOTOR CURRENT SENSE CIRCUIT

The voltage drop across sensing resistors R15, R16, and R17 on the Power PCB is proportional to the current through the drive motor. This voltage is applied to the current limit input of U1 at pins 8 and 9 through comparator U3A and inverter U2E. This is a negative feedback loop that counteracts the PWM pulse to limit current draw of the motor.

FAN CONTROL CIRCUIT

Neutral side of FL1 output (115VAC) is applied to the fan motor (MOT2). The high side is supplied to Q1 on the Display / Control PCB through pin 1 of connector FAN1. The fan control signal is from U1 pin 34 to input of U6 at pin 2. The output of U6 at pin 4 is applied to Q1. The output of the Q1 is applied through FAN1 pin 3 to the fan motor (MOT2).

MOTOR BRAKING CIRCUIT

After the end of the cycle U1 pins 12 and 13 on the Display / Control PCB go low turning off the run mode and the Drive / Brake Relay. Turning off the Drive / Brake Relay connects the three brake resistors to the motor through the Drive / Brake Relay's normally closed (NC) and common (COM) contacts.

Functional Description

When the Drive / Brake Relay turns off, the kinetic energy stored in the spinning rotor is converted to electrical energy by the motor. This voltage is applied to the brake resistors through the relay contacts. The load supplied by the brake resistors dissipates the stored energy.

The speed at which the brake turns on depends upon the brake level setting. The brake will engage immediately when an error occurs.

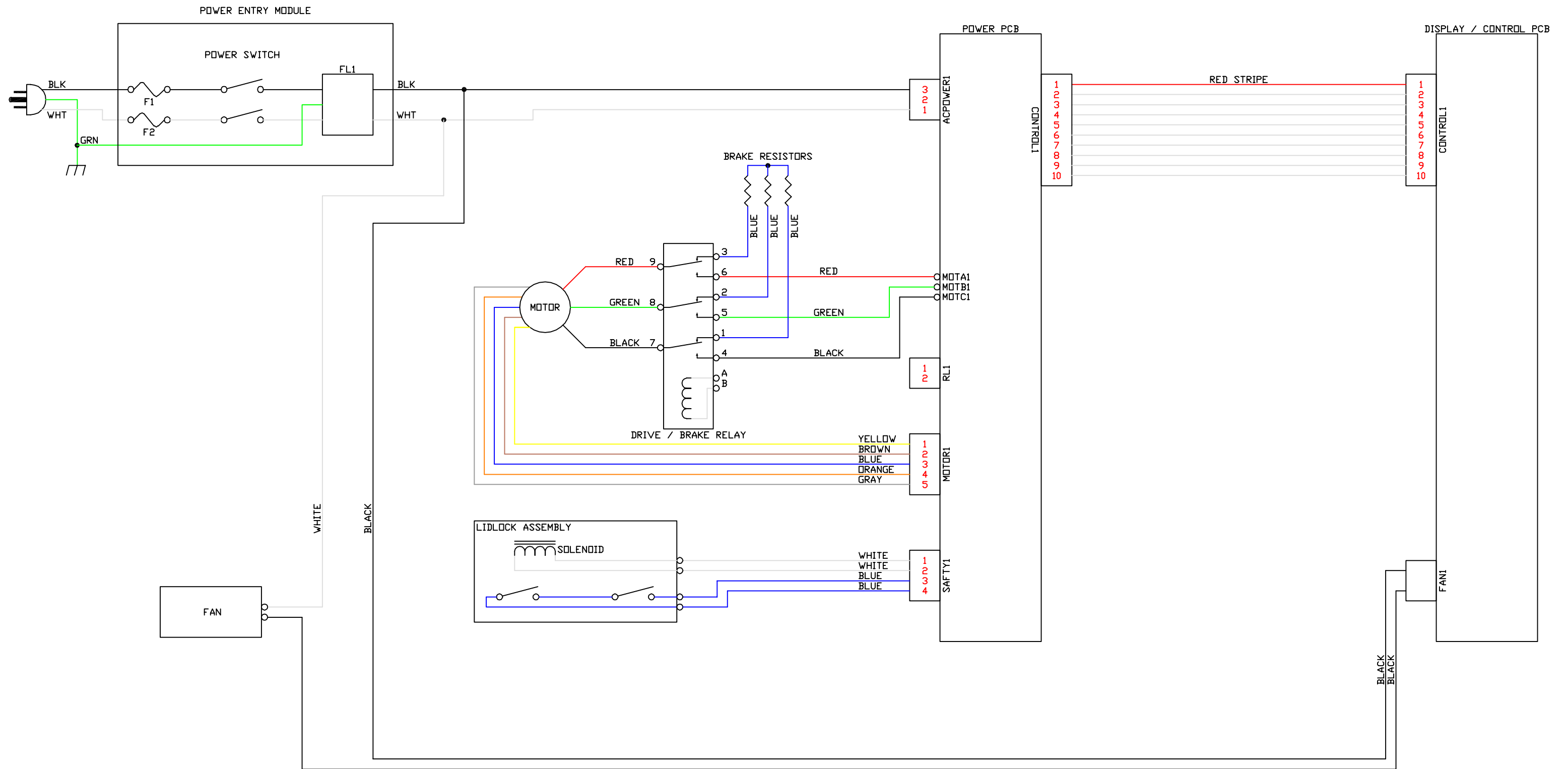

Figure 7.1
Wiring Diagram
Page 7-1

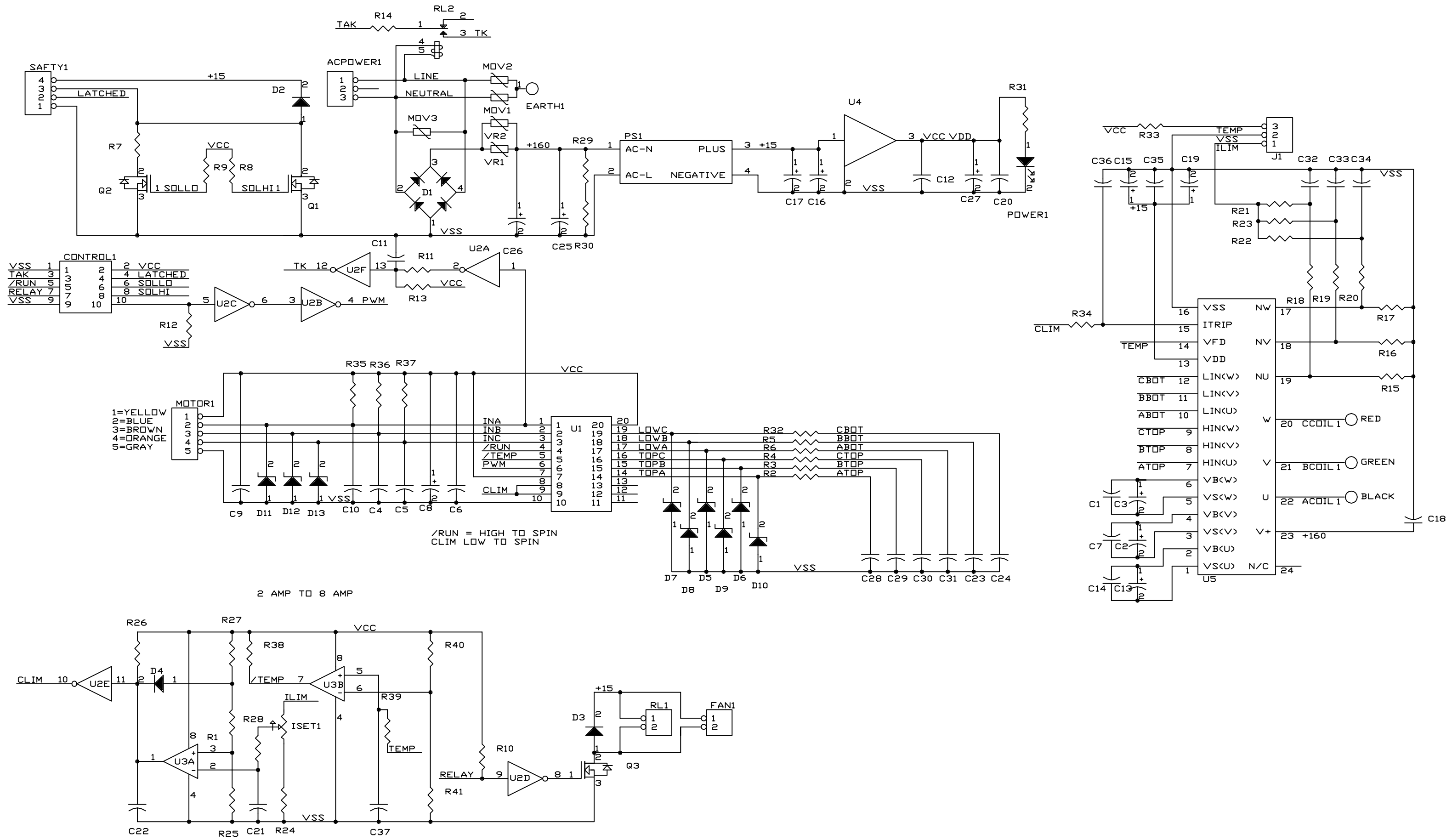

Figure 7.2
Power P.C.B. Schematic
Page 7-2

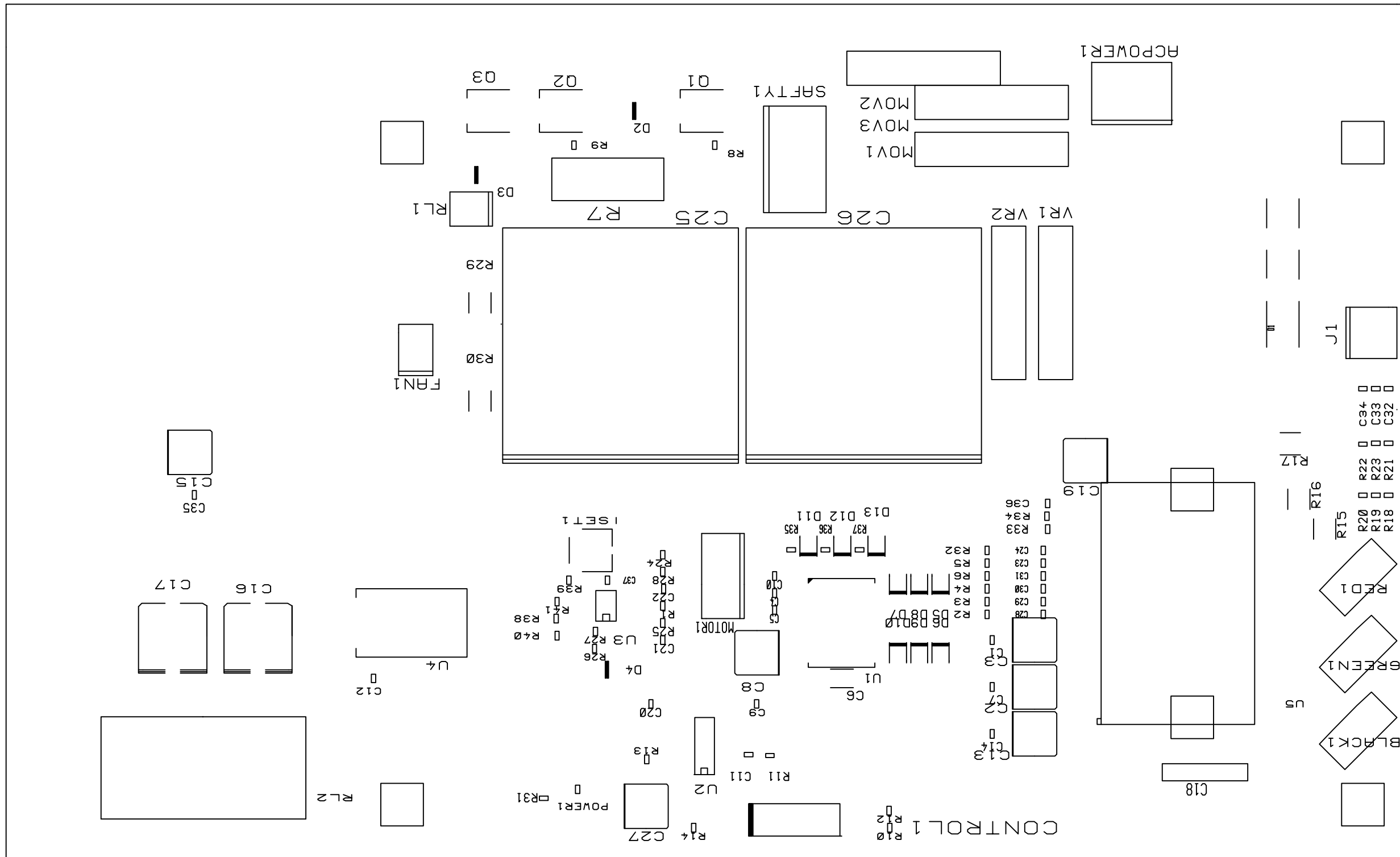

Figure 7.3
Power P.C.B. Layout
Page 7-3

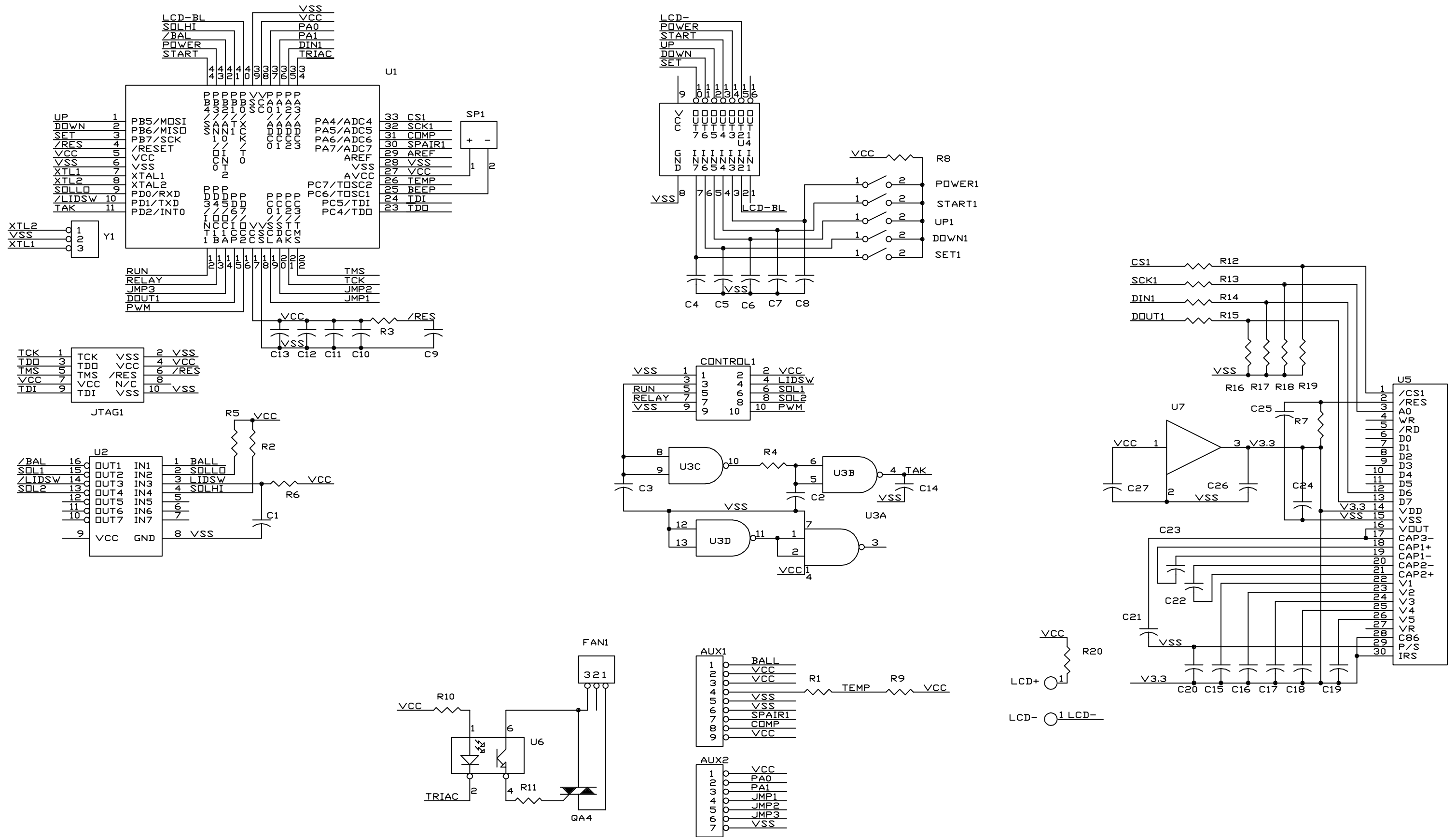

Figure 7.4
 Display / Control P.C.B. Schematic
 Page 7-4

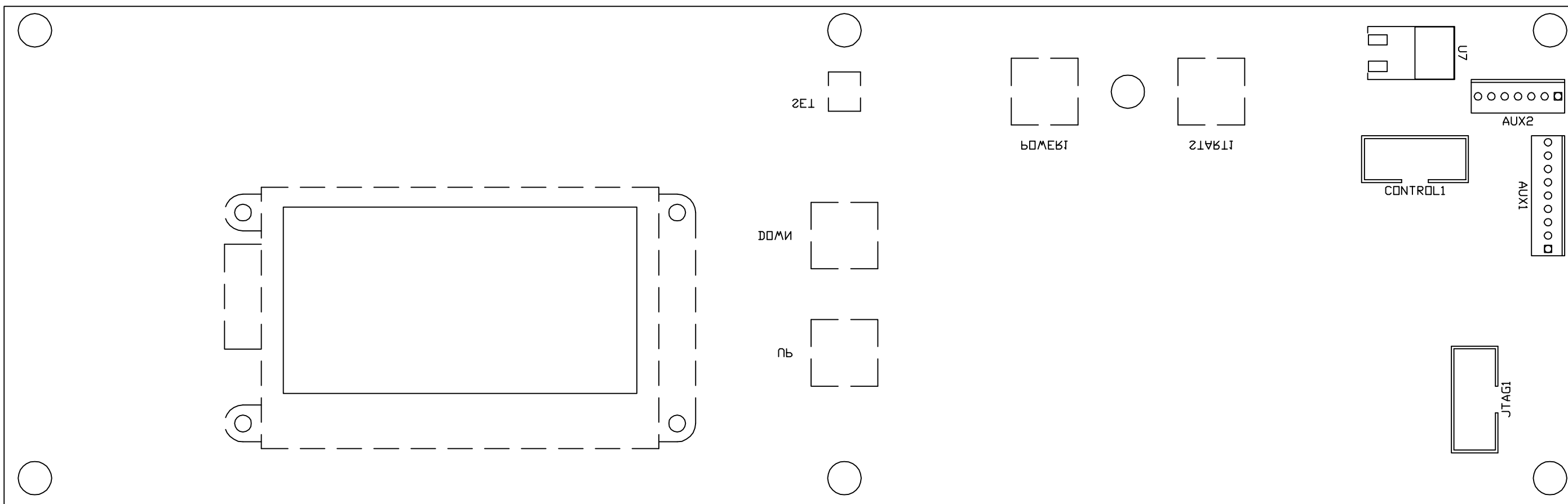
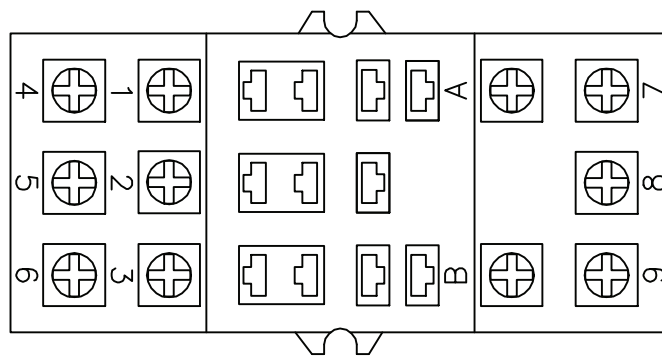

Figure 7.5
 Display / Control P.C.B. Layout
 Page 7-5



- A (COIL) = WHITE - POWER PCB (RL1)
- B (COIL) = WHITE - POWER PCB (RL1)
- 1 (NC) = BLUE - BRAKE RESISTOR
- 2 (NC) = BLUE - BRAKE RESISTOR
- 3 (NC) = BLUE - BRAKE RESISTOR
- 4 (NO) = BLACK - POWER PCB (MOTC1)
- 5 (NO) = GREEN - POWER PCB (MOTB1)
- 6 (NO) = RED - POWER PCB (MOTA1)
- 7 (COM) = BLACK - MOTOR
- 8 (COM) = GREEN - MOTOR
- 9 (COM) = RED - MOTOR

Figure 7.6
Drive / Brake Relay Socket Wiring
Page 7-6

Chapter 8

Parts Replacement Procedures

PRECAUTIONS

This section describes procedures for replacement of parts which may not be obvious to complete. **Remove power and read the entire procedure carefully prior to beginning any procedure! Pay particular heed to all WARNINGS and CAUTIONS.**



WARNING

Turning the power off does not remove power to the centrifuge. Remove all power to the unit by unplugging the power cord.

EQUIPMENT

The following equipment is useful or necessary in the repair of the ELITE centrifuge.

- A Test Equipment
 1. Tachometer
 2. Multimeter
 3. Ammeter (capacity to 10 amps)
- B. Tools
 1. Screwdrivers (assorted slotted and Phillips)
 2. Nut Drivers (5/16" minimum requirement)
 3. Hex (Allen) Wrenches
 4. Adjustable Wrench

MOTOR

Turn on power to the ELITE. Open the lid, turn the power off, and **unplug the power cord.**

Remove the four Phillips front panel retaining screws (see Figure 8.1) taking care not to drop the front panel. Lower the front panel.

Unplug the motor and tach sensor connectors.

Remove the rotor retaining nut, and gently lift the rotor off.

CAUTION

Take care not to drop anything onto the PCB's or into the unit to prevent possible damage to the unit.

Parts Replacement Procedures

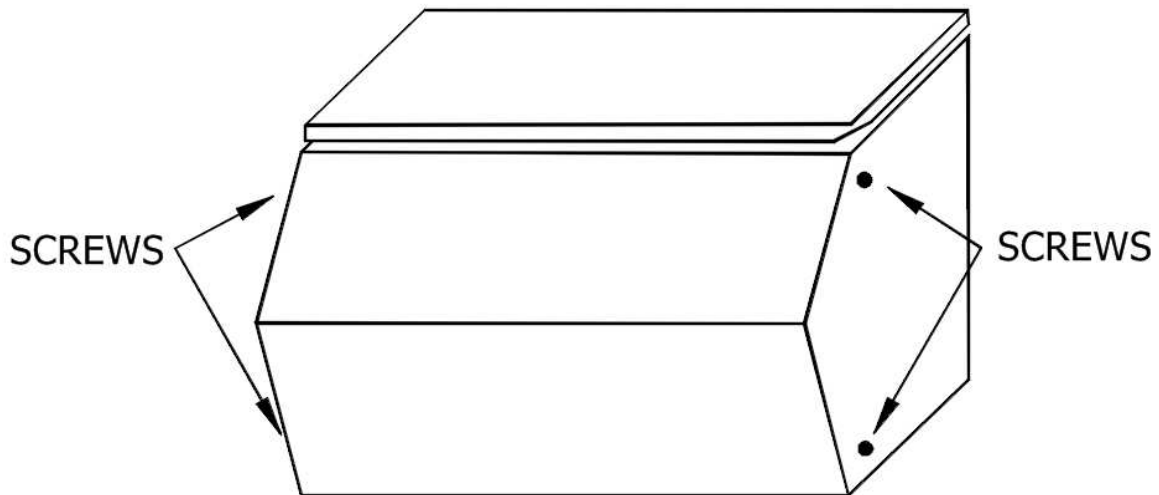

Figure 8.1

Remove the rubber motor gasket by rolling the outer edge back, unhook it from the rotor chamber (see Figure 8.2), and then pull it from around the motor.

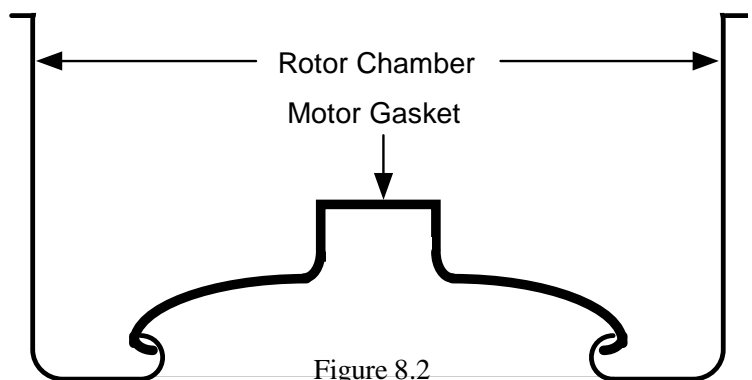

Figure 8.2

Remove the four Phillips head screws from the motor mount (see Figure 8.3), and remove the motor assembly.

Reverse procedure to re-install the motor.

Lightly grease the motor shaft before reinstalling the rotor.

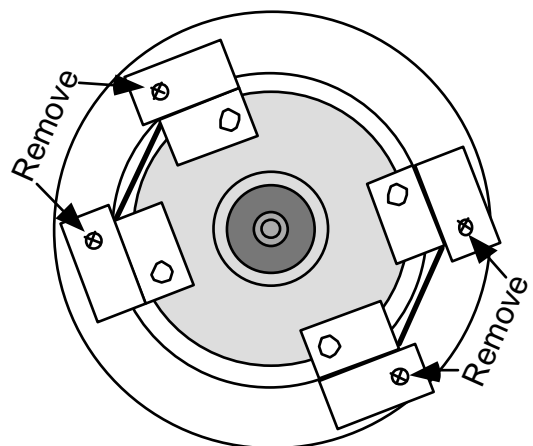

Figure 8.3

CAUTION

Take care not to drop anything onto the PCB's or into the unit to prevent possible damage to the unit.

Parts Replacement Procedures

DISPLAY / CONTROL PCB

Unplug the power cord.

Remove the four Phillips front panel retaining screws (see Figure 8.1) taking care not to drop the control panel. Lower the control panel.

Remove all plug connections, and mounting screws.

Remove the Display / Control P.C.B.

Install replacement Display / Control P.C.B. by reversing the removal procedure.

POWER PCB

Unplug the power cord.

Remove the four Phillips front panel retaining screws (see Figure 8.1) taking care not to drop the control panel. Lower the control panel.

Remove all plug connections, and mounting screws.

Remove the Power P.C.B.

Install replacement Power P.C.B. by reversing the removal procedure.

LIDLOCK ASSEMBLY

Unplug the power cord.

Remove the four Phillips front panel retaining screws (see Figure 8.1) taking care not to drop the control panel. Lower the control panel.

Unplug the connector to the Lidlock Assembly.

Remove the two 5/16" hex nuts securing the Lidlock Assembly.

Install replacement Lidlock Assembly by reversing the removal procedure.

DRIVE / BRAKE RELAY

Unplug the power cord.

Remove the four Phillips front panel retaining screws (see Figure 8.1) taking care not to drop the control panel. Lower the control panel.

Unplug the relay from the socket.

CAUTION

Take care not to drop anything onto the PCB's or into the unit to prevent possible damage to the unit.

Parts Replacement Procedures

Plug new relay into the socket.

DRIVE / BRAKE RELAY SOCKET

Unplug the power cord.

Remove the four Phillips front panel retaining screws (see Figure 8.1) taking care not to drop the control panel. Lower the control panel.

Unplug the relay from the socket.

Disconnect the eleven wires connected to the relay socket, noting which wire attaches to which screw terminal.

Remove the two Phillips screws securing the relay socket to the base of the centrifuge, noting the orientation of the socket.

Attach the new relay socket to the base of the centrifuge with the two Phillips screws oriented the same way as the original socket.

Attach the eleven wires to the new relay socket in same positions as they were removed from the original socket. Please see Figure 7.6 for wiring orientation.

Plug the relay into the socket.

CAUTION

Connecting the wires to the wrong screw terminal can seriously damage your centrifuge.

CAUTION

Take care not to drop anything onto the PCB's or into the unit to prevent possible damage to the unit.

Chapter 9

Limited Warranty Statement

New Silencer® centrifuges are warranted to be free from defects in material and workmanship for a period of one year from the date of delivery. GFMD, Ltd., or its agent, will repair or replace and return free of charge any part that is returned, transportation prepaid by user, to GFMD, Ltd., or its agent, within said period, and that is found upon inspection to have been defective in materials or workmanship.

There is an additional one year warranty on parts plus an additional three years on the motor. During this period GFMD, Ltd., or its agent, will repair or replace and return free of charge any part that is returned, transportation prepaid by user, to GFMD, Ltd., or its agent, within said period, and that is found upon inspection to have been defective in materials or workmanship. Labor is not included during this period.

These warranties do not include normal wear from use, or operator maintenance. It does not apply to any instrument or part that has been altered by anyone other than an employee of the manufacturer or its agent nor to any instrument that has been damaged through accident, negligence, failure to follow operating instructions, natural disaster, the use of electric currents of circuits other than those specified on the plate affixed to the instrument, insufficient or excessive electrical supply, operation on emergency or backup generators, abnormal mechanical or environmental conditions, misuse or abuse.

GFMD, Ltd. reserves the right to change, alter, modify or improve any of its instruments without any obligation whatsoever to make corresponding changes to any instrument previously sold or shipped.

The foregoing obligations are in lieu of all other obligations including negligence and all warranties of merchantability or otherwise, expressed or implied in fact or by law and state our entire and exclusive liability and buyer's exclusive remedy for any claim or damages in connection with the sale or furnishing of goods or parts, their design, suitability for use, installation or operation. GFMD, Ltd., or its agent, will in no event be liable for any special or consequential damages whatsoever, and our liability under no circumstances will exceed the contract price for the goods for that liability is claimed.

Appendix A

Specifications

PERFORMANCE SPECIFICATIONS

- Maximum speed:
 - ELITE-H12 w/ 12 x 10ml Horizontal Rotor 4,500 RPM
 - ELITE-F24 w/ 24 x 10ml FA Rotor 5,000 RPM
 - ELITE-PPP w/ 12 x 5ml FA Rotor 7,000 RPM
 - ELITE-SC w/ 8 x 5ml FA Rotor 7,000 RPM

- Maximum RCF:
 - ELITE-H12 w/ 12 x 10ml Horizontal Rotor 3,060 x g
 - ELITE-F24 w/ 24 x 10ml FA Rotor 3,651 x g
 - ELITE-PPP w/ 12 x 5ml FA Rotor 5,237 x g
 - ELITE-SC w/ 8 x 5ml FA Rotor 5,497 x g

- Approximate acceleration rate (0 - Max. RPM): 10 seconds

- Approximate deceleration rate (Max. - 0 RPM):
 - ELITE-H12 w/ 12 x 10ml Horizontal Rotor 20 seconds
 - ELITE-F24 w/ 24 x 10ml FA Rotor 30 seconds
 - ELITE-PPP w/ 12 x 5ml FA Rotor 30 seconds
 - ELITE-SC w/ 8 x 5ml FA Rotor 30 seconds

- Maximum noise level - Horizontal rotor 58 dBA

- Speed Control +/- 2%

- Timer +/- 5%

- Power requirements - 115 volts, 5 amperes

UNIT SPECIFICATIONS

- Dimensions 13”w x 16.5”d x 11.5”h
- Spill resistant control panel
- Completely enclosed rotor chamber
- High-strength alloy rotor chamber
- See-through high-strength lid
- Dual safety interlock to ensure lid is closed and locked
- Direct drive system
- Brushless D.C. motor (2/3 HP)
- Microprocessor control
- Digital speed display
- Digital R.C.F. display
- Digital time display
- Timer range 1 - 999 plus hold
- Variable automatic dynamic braking system

Appendix B

R.C.F. Chart

RELATIVE CENTRIFUGAL FORCE CHART						
RPM	R.C.F.					
	ELITE-H12 w/ 12 x 10ml Hz Rotor		ELITE-F24 w/ 24 x 10ml FA Rotor†		ELITE-PPP w/ 12 x 5ml FA Rotor	ELITE-SC w/ 8 x 5ml FA Rotor
		w/ 5ml Adapter		w/ 5ml Adapter		
500	38	32	37	32	27	28
600	54	46	53	46	38	40
700	74	63	72	63	52	55
800	97	82	93	82	68	72
900	122	104	118	104	87	91
1,000	151	128	146	128	107	112
1,100	183	155	177	155	129	136
1,200	218	185	210	185	154	162
1,300	255	217	247	217	181	190
1,400	296	252	286	251	209	220
1,500	340	289	329	289	240	252
1,600	387	329	374	328	274	287
1,700	437	371	422	371	309	324
1,800	490	416	473	416	346	363
1,900	546	464	527	463	386	405
2,000	605	514	584	513	427	449
2,100	666	566	644	566	471	495
2,200	731	621	707	621	517	543
2,300	799	679	772	679	565	593
2,400	870	740	841	739	616	646
2,500	945	803	913	802	668	701
2,600	1,022	868	987	867	722	758
2,700	1,102	936	1,065	935	779	818
2,800	1,185	1,007	1,145	1,006	838	880
2,900	1,271	1,080	1,228	1,079	899	943
3,000	1,360	1,156	1,314	1,155	962	1,010
3,100	1,452	1,234	1,403	1,233	1,027	1,078
3,200	1,548	1,315	1,495	1,314	1,094	1,149
3,300	1,646	1,398	1,590	1,397	1,164	1,222
3,400	1,747	1,484	1,688	1,483	1,235	1,297
3,500	1,851	1,573	1,789	1,572	1,309	1,374
3,600	1,959	1,664	1,893	1,663	1,385	1,454
3,700	2,069	1,758	1,999	1,757	1,463	1,536

RELATIVE CENTRIFUGAL FORCE CHART						
RPM	R.C.F.					
	ELITE-H12 w/ 12 x 10ml Hz Rotor		ELITE-F24 w/ 24 x 10ml FA Rotor†		ELITE-PPP w/ 12 x 5ml FA Rotor	ELITE-SC w/ 8 x 5ml FA Rotor
		w/ 5ml Adapter		w/ 5ml Adapter		
3,800	2,182	1,854	2,109	1,853	1,543	1,620
3,900	2,299	1,953	2,221	1,952	1,626	1,706
4,000	2,418	2,054	2,336	2,053	1,710	1,795
4,100	2,540	2,158	2,455	2,157	1,797	1,886
4,200	2,666	2,265	2,576	2,263	1,885	1,979
4,300	2,794	2,374	2,700	2,373	1,976	2,074
4,400	2,926	2,486	2,827	2,484	2,069	2,172
4,500	3,060	2,600	2,957	2,598	2,164	2,272
4,600			3,090	2,715	2,261	2,374
4,700			3,226	2,834	2,361	2,478
4,800			3,365	2,956	2,462	2,585
4,900			3,506	3,081	2,566	2,694
5,000			3,651	3,208	2,672	2,805
5,100					2,780	2,918
5,200					2,890	3,033
5,300					3,002	3,151
5,400					3,116	3,271
5,500					3,233	3,394
5,600					3,352	3,518
5,700					3,472	3,645
5,800					3,595	3,774
5,900					3,720	3,905
6,000					3,847	4,039
6,100					3,977	4,174
6,200					4,108	4,312
6,300					4,242	4,453
6,400					4,378	4,595
6,500					4,515	4,740
6,600					4,655	4,887
6,700					4,798	5,036
6,800					4,942	5,187
6,900					5,088	5,341
7,000					5,237	5,497

† Maximum R.C.F. for outer row of tube holders. For inner row multiply the R.C.F. for outer row by .885.

Service Log

Service Log		
Date	Service Performed	By

Appendix D

Replacement Parts List

Description	Qty Needed	Part No.
Gasket, Lid	1 ea.	SIL00476
Gasket, Motor, ELITE-PPP / -SC	1 ea.	SIL00456A
Gasket, Motor, ELITE-H12 / -F24	1 ea.	SIL00456B
Hinge, Lid, MACH / ELITE	2 ea.	SIL00512
Latch, Lidlock	1 ea.	SIL00642B
Lid, MACH / ELITE	1 ea.	SIL00661
Lidlock Assembly	1 ea.	SIL00671B
Solenoid (part of SIL00671B)	1 ea.	SIL00131
Switch, Lid Interlock (part of SIL00671B)	1 ea.	SIL02456
Switch, Lock Interlock (part of SIL00671B)	1 ea.	SIL02457
Motor Assembly, ELITE-H12 / -F24	1 ea.	SIL00730B
Motor Assembly, ELITE-PPP / -SC	1 ea.	SIL00730D
Nut, Rotor Securing	1 ea.	SIL00791
P.C.B., Display / Control, ELITE / STEALTH	1 ea.	SIL00816B
P.C.B., Power, MACH / ELITE / STEALTH	1 ea.	SIL00841
Relay, Drive / Brake	1 ea.	SIL01103

Parts are sold individually. The quantity listed is the quantity used per unit.

Lid Release Tool



WARNING

The lid release tool is provided for emergency access to samples only. Unplug the centrifuge before attempting this procedure!

The correct tool must be used for your unit or the lid safety interlock switch may become damaged. If the interlock switch is damaged the unit can't detect the lid being closed and therefore won't start.

To use the release tool:

1. Unplug the centrifuge.
2. Insert the tool completely into the release access port on the left side of the unit (just below the lid locking bracket).
3. Push the handle towards the back of the unit and lift the centrifuge lid.

Appendix F

Motor Hall Effect Sensor Testing

⚠ WARNING

Follow standard safety precautions for handling of potential biological hazards!

The motor has three Hall effect sensors that are used for angular position information to determine which phase needs to be energized. Hall effect sensor A is also tach feedback for speed control. Some models do not have the DRIVE / BRAKE RELAY and the BRAKE RESISTORS but the Hall effect sensor testing is the same.

1. MOTOR1 pin 1 (yellow) is VCC (+5 VDC).
2. MOTOR1 pin 5 (gray) is VSS (common).
3. Measure the DC voltage from VSS to MOTOR1 pin 2 (brown) while slowly turning the rotor by hand.
4. The voltage should switch between high and low (> 4 VDC and < 1 VDC).
5. Repeat steps 3 and 4 for MOTOR1 pin 3 (blue) and MOTOR1 pin 4 (orange).

